

4000 Series

4012TWG

Diesel Engine –
Electro Unit

711 kWm 1200 rev/min
957 kWm 1500 rev/min

The Perkins 4000 Series family of 6, 8, 12 and 16 cylinder diesel engines was designed in advance of today's uncompromising demands within the power generation industry and includes superior performance and reliability.

The 4012TWG is a turbocharged, air to water charge cooled, 12 cylinder vee form diesel engine. Its premium design and specification features provide economic and durable operation as well as exceptional power to weight ratio, improved serviceability, low gaseous emissions, overall performance and reliability essential to the power generation market.

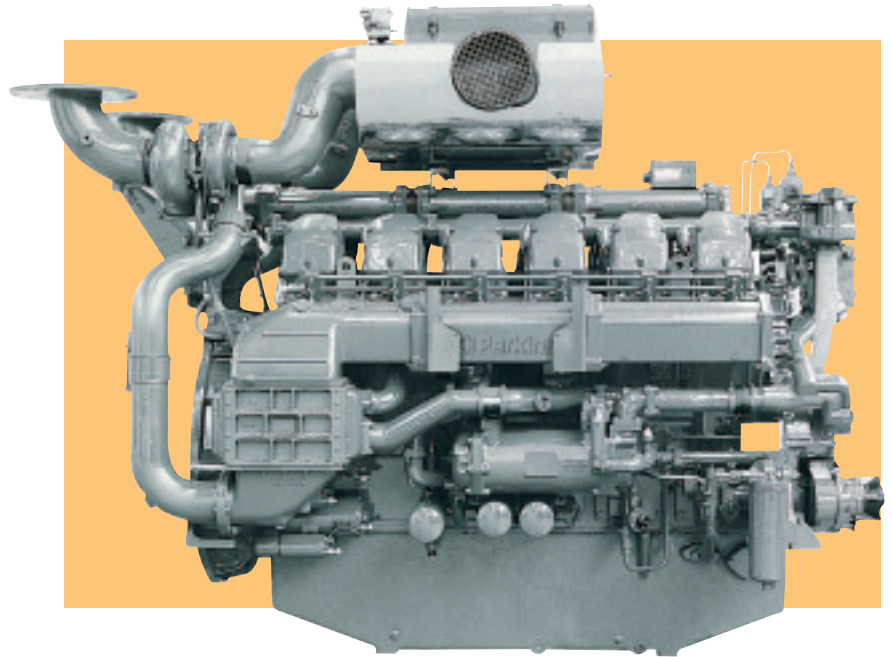

Economic power

- Individual 4 valve cylinder heads giving optimised gas flows.
- Unit fuel injectors ensure ultra fine fuel atomisation and hence controlled rapid combustion.
- Commonality of components with other engines in 4000 Series family for reduced stocking levels.

Reliable power

- Developed and tested using latest engineering techniques.
- Piston temperatures controlled by an advanced gallery jet cooling system.
- Tolerant of a wide range of temperatures without derate.
- Over 4000 distributors and dealers worldwide.

Clean, efficient power

- Exceptional power to weight ratio and compact size for easier transportation and installation.
- Designed to provide excellent service access for ease of maintenance.
- Engines designed to comply with major international standards.
- Low gaseous emissions.

Engine Speed rev/min	Type of Operation	Typical Generator Output (Net)		Engine Power			
		kVA	kWe	Gross		Net	
				kWm	bhp	kWm	bhp
1200	Continuous baseload	590	472	571	766	497	666
	Prime power	760	608	714	957	640	858
	Standby (maximum)	844	675	785	1053	711	953
1500	Continuous baseload	819	655	714	957	690	924
	Prime power	1031	825	892	1196	868	1164
	Standby (maximum)	1136	909	981	1315	957	1283

The above ratings represent the engine performance capabilities guaranteed within plus or minus 3% at the reference conditions equivalent to those specified in ISO 8528/1, ISO 3046/1, BS5514/1.

Ratings conditions: 25°C air inlet temperature, barometric pressure 100 kPa, relative humidity 30%. Please consult your distributor or the factory for ratings in other ambient conditions.

Note: For full ratings please refer to Perkins Engines Company Limited. All electrical ratings are based on an average alternator efficiency and a power factor of 0.8.

Fuel specification: BS2869 Class A1 + A2 or ASTM D975 No 2D.

Rating Definitions

Continuous baseload – Power available for continuous full load operation. No overload is permitted.

Prime power – Power available for variable load with an average load factor not exceeding 80% of the prime power rating in any 24 hour period. Overload of 10% permitted for 1 hour in every 12 hours operation.

Standby maximum – Power available at variable load in the event of a main power network failure for a maximum of 500 hours per year. No overload is permitted.

Standard Electro Unit Specification

Governing

- Electronic governor to ISO 3046 part 4 (BS5514/4) A1

Electrical equipment

- 24 volt electrical equipment comprising twin starter motors, battery charging alternator with integral voltage regulator and activating switch

Flywheel and housing

- SAE 18 flywheel, SAE 00 housing

Fuel system

- Direct fuel injection system, fuel lift pump, hand stop control

Lubrication system

- Lubricating oil filters
- Engine jacket water/oil temperature stabilizer

Cooling system

- Two twin thermostats, two water pumps
- Free end crankshaft pulley

Engine protection

- 24 volt stop solenoids (energised to run)
- Combined high coolant – temperature/low oil pressure switch
- Overspeed switch and magnetic pickup
- Induction air shut-off valves
- Thermocouples for exhaust temperature

Optional Equipment

The following optional extra equipment is available to make up the specifications to the Perkins

ElectropaK specification:

- Tropical radiator including:
Water pipes, clips and hoses
Fan, fan guards and belts

Other optional extra equipment available

- Twin heavy duty air cleaners – paper element with pre-cleaner
- Changeover lubricating oil filters
- Changeover fuel oil filters
- Immersion heater with thermostat
- Water pipes, clips and hoses for radiator
- Air starters
- Instrument panel

NB This list is not exhaustive, further options may be available to meet particular applications on enquiry to Perkins Sales Department



Perkins Engines Company Limited

Tixall Road Stafford ST16 3UB England
Telephone (01785) 223141 Telex 36156
Fax (01785) 215110
www.perkins.com

All information given in this leaflet is correct at the time of printing, but it may be changed subsequently by the Company.

General Data

Number of cylinders	12
Cylinder arrangement	60° Vee form
Cycle	4-stroke
Induction system	Turbocharged. Air to water charge cooled
Combustion system	Direct injection
Cooling system	Water-cooled
Displacement	45.842 litres
Bore and stroke	160 mm x 190 mm
Compression ratio	13.6:1
Direction of rotation	Anti-clockwise, viewed from flywheel end
Firing order	1A,6B,5A,2B,3A,4B 6A,1B,2A,5B,4A,3B
Total lubrication system capacity	177.6 litres

	Electro Unit	ElectropaK
Total coolant capacity	73 litres	210 litres
Total weight (dry)	4360 kg	4975 kg
Length	2715 mm	3795 mm
Width	1440 mm	1870 mm
Height	2120 mm	2211 mm

Fuel consumption g/kWh		
Engine speed	1200 rev/min	1500 rev/min
At standby maximum power rating	209	211
At prime power rating	206	205
At continuous baseload rating		
At 75% of prime power rating	200	211
At 50% of prime power rating	201	226
At 25% of prime power rating	208	270

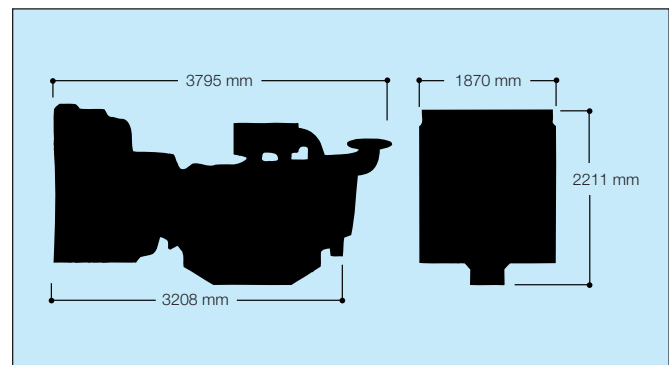

Distributed by