

# 3000 Series

# 3012-26TA4

Diesel Engine –  
Industrial Open Power Unit

675kWm / 905bhp

**The Perkins 3000 Series Industrial Open Power Units are a family of 12-cylinder vee form heavy-duty engines offering a range of outputs from a common package.**

Specifically developed from the highly successful Electropak and CV12 military packages, these 26.1 litre engines offer exceptional power and life for all stationary industrial applications.

Premium design features of the 3012 Series IOPUs offer durability and economy whilst developing high power and torque from a compact low weight package.

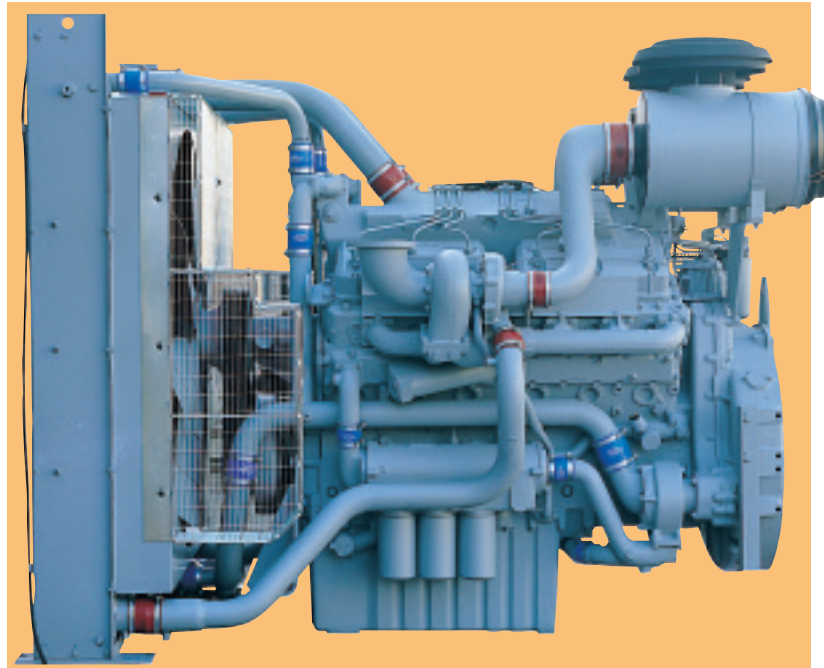

Note: Radiator /charge cooler package is supplied loose

## Reliable and durable power

- **High-grade cast iron cylinder block and heads** are designed for high powers and heavy duties while the deep-skirted crankcase provides extra crankshaft support and strength.
- **Unique slip-fit dry liners** are centrifugally-cast, precision bored and plateau honed for rapid ring bedding giving excellent oil control and longer life.
- **Precision balanced nitride hardened forged steel crankshafts** give exceptional life while matched and balanced pistons, con-rods and flywheels ensure smooth running at all operating speeds.

## Proven performance

- **Perkins outstanding reputation comes from our world class manufacturing capability.** Internationally recognised and customer approved quality procedures ensure unsurpassed reliability.

## Economic power

- **The high efficiency** provided by a high compression combustion system with directed inlet ports and four valves per cylinder contributes to low running costs.

## Designed to fit

- **Perkins industrial open power units** offer a complete package with matched cooling system for easy installation and ready to run.

## Worldwide support

- **Perkins' network of 4000 distributors and dealers** assures the operator of the highest standards of in-service technical and parts support.

Performance Data	Net intermittent	Speed rev/min	Net continuous	Speed rev/min
Power Output (kW)	675	1800	615	1800
Power Output (bhp)	905	1800	825	1800
Peak Torque (Nm)	4120	1200	3740	1200
Peak Torque (lbf ft)	3038	1200	2758	1200

Performance data quoted in accordance with ISO3046/BS5514/DIN6271 conditions

# 3000 Series

# 3012-26TA4

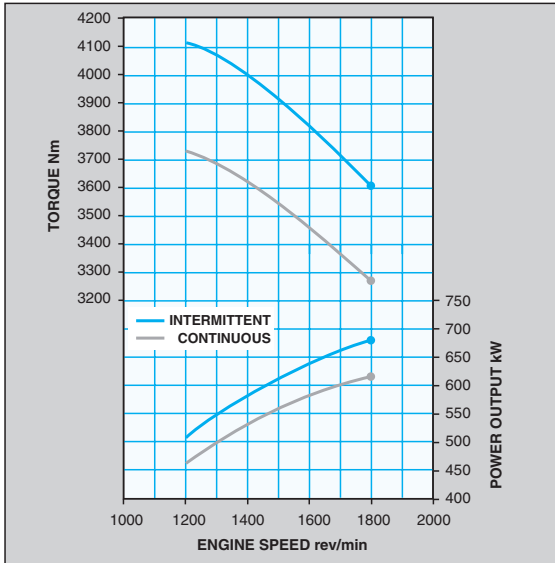

Performance and tolerances to ISO3046/BS5514/DIN6271

## Standard specification

- Mounted 13" air filters
- 24Volt 40 Amp alternator
- 24 Volt starter
- 1220 mm pusher fan
- Radiator/charge cooler, piping and fan guard supplied loose
- Flywheel to SAE J620 size 18
- Flywheel housing SAE 0
- In-line fuel injection pump and twin full-flow fuel filters
- All-speed servo-assisted mechanical governor
- Speed control lever
- Senders/switches for coolant temperature and oil pressure
- 24 Volt shutdown solenoid
- Oil cooler with triple full-flow filters
- Wet sump
- Twin turbochargers with exhaust elbow
- Front engine mounting foot
- User's handbook and parts manual

## Optional equipment

- Twin starter motors
- Air filter pre-cleaner
- Twin immersion heaters 110V or 220/240V 1500 Watt
- Tool kit
- Workshop manual

This list is not exhaustive – please consult your Perkins dealer

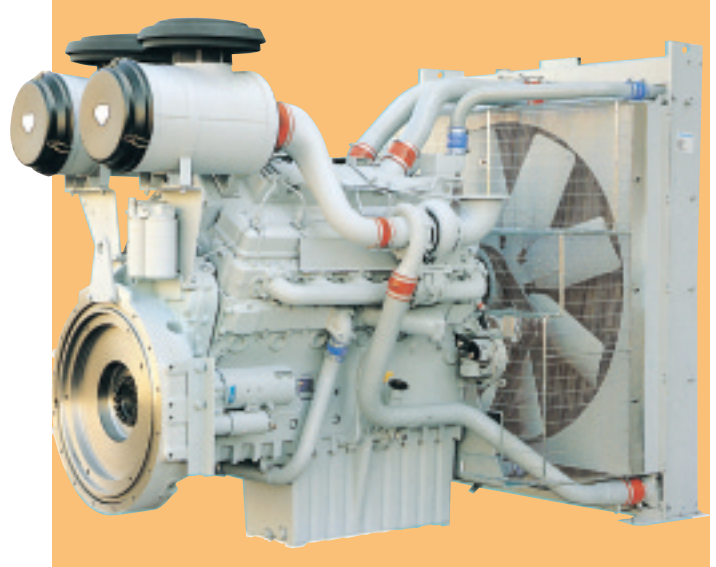

## General data

<b>Bore and stroke</b>	135 x 152mm
<b>No of cylinders</b>	12, 60° vee form
<b>Cubic capacity</b>	26.11 litres
<b>Cycle</b>	4 stroke
<b>Aspiration</b>	Turbocharged air-to-air charge cooled
<b>Combustion system</b>	Direct injection
<b>Compression ratio</b>	14.5:1
<b>Firing order</b>	A1.B6.A4.B3.A2.B5 A6.B1.A3.B4.A5.B2.
<b>Rotation</b>	Anticlockwise viewed on flywheel
<b>Governing</b>	Servo-assisted mechanical all-speed
<b>Cooling</b>	Thermostatically-controlled pressurised liquid cooled
<b>Coolant capacity</b>	122.7 litres
<b>Lubricating oil capacity</b>	73.8 litres
<b>Weight (dry)</b>	2365 kg (including starter and alternator)

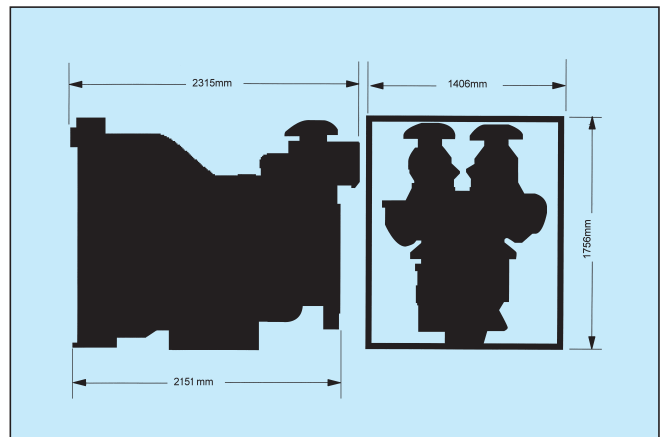

**Perkins Engines Company Limited**

Lancaster Road, Shrewsbury, SY1 3NX England  
 Telephone +44(0)1743 212000  
 Fax +44(0)1743 212700  
 www.perkins.com

All information in this leaflet is substantially correct at the time of printing but may be changed subsequently by the Company.