

3000 Series

3008TAG4

Diesel Engine –
Electropak

468 kWm 1500 rev/min

The Perkins 3000 Series is a family of well proven 8 and 12 cylinder vee form diesel engines designed in advance of today's uncompromising demands within the power generation industry including superior performance and reliability.

The 3008TAG4 is a turbocharged and air-to-air charge cooled 8 cylinder diesel engine. Its premium design and specification features provide economic and durable operation as well as exceptional power to weight ratio, commonality of components, improved serviceability, low gaseous emissions, overall performance and reliability essential to the power generation market.

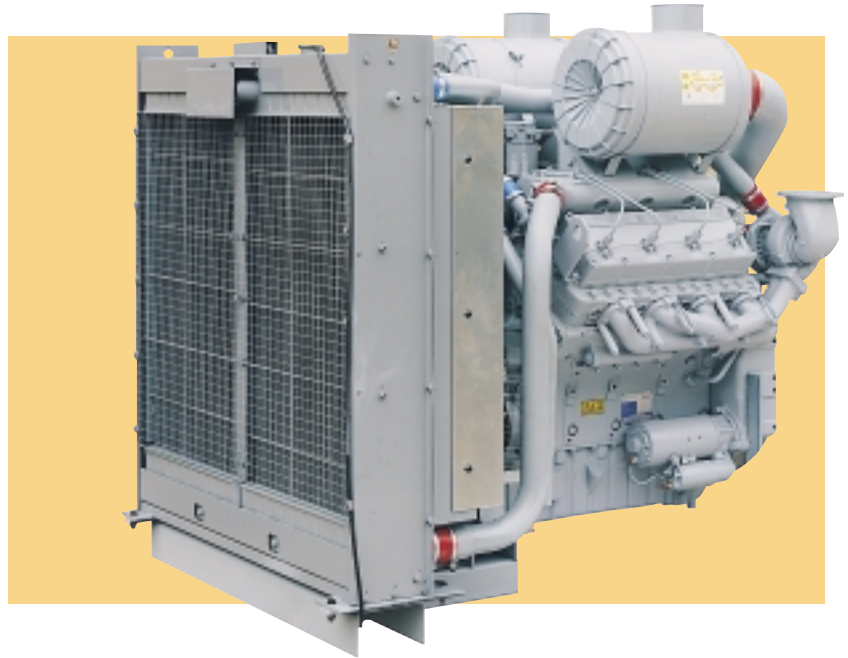

Economic power

- **Directed inlet ports** in monobloc cylinder heads give optimised gas flows. High compression ratios combined with high injection pressures ensure ultra fine fuel atomisation and controlled rapid combustion with low emissions. Commonality of components with other engines in the 3000 Series family for reduced stocking levels.

Reliable power

- **Developed and tested** using latest engineering techniques and finite element analysis for high reliability. Low oil usage and low wear rates. High compression ratios also ensure clean rapid starting in all conditions.
A worldwide network of 4000 distributors and dealers.

Compact, efficient power

- **Exceptional power to weight ratio** and compact size give optimum power density and make installation and transportation easier. Designed to provide excellent service access for ease of maintenance.

Engine Speed rev/min	Type of Operation	Typical Generator Output (Net)		Engine Power			
		kVA	kWe	Gross		Net	
				kW	bhp	kW	bhp
1500	Continuous Baseload	-	-	-	-	-	-
	Prime Power	500	400	438	587	426	571
	Standby (Maximum)	550	440	480	644	468	628
1800	Continuous Baseload	-	-	-	-	-	-
	Prime Power	-	-	-	-	-	-
	Standby (Maximum)	-	-	-	-	-	-

The above ratings represent the engine performance capabilities to conditions specified in ISO 8528/1, ISO 3046/1:1986, BS 5514/1.

Derating may be required – consult Perkins Engines.

Fuel specification: BS 2869 Class 2 or ASTM D975 D2. **Lubricating Oil:** 15W40 to ACEA E3.

Genset Powers are typical and are calculated on an average alternator efficiency, and power factor (cos θ) of 0.8.

Rating Definitions

Prime Power – Power available at variable load with an average load factor not exceeding 80% of the Prime Power rating. Overload of 10% permitted for 1 hour in every 12 hours' operation.

Standby (Maximum) – Power available at variable load in the event of a main power network failure up to a maximum of 500 hours per year. No overload is permitted.

NOTE: This engine is not available for Baseload duty.

Standard ElectropaK Specification

Air Inlet

- Mounted air filters

Fuel System

- In-line fuel injection pump with mechanical governor. Governing to ISO 3046/4:1986 (BS 5514/4) Class A1
- Spin-on fuel filters with primary filter/water separator

Lubrication System

- Wet sump with filler and dipstick
- Full-flow 'spin-on' filters; oil cooler incorporated in filter header

Cooling System

- Gear-driven circulating pump
- Mounted belt-driven fan
- Radiator supplied loose incorporating air-to-air charge cooler
- System designed for ambients up to 48°C (non-glycol)

Electrical Equipment

- 24 Volt starter motor and 24V 40 Amp alternator with DC output
- 24 Volt instrument senders/switches for oil pressure, coolant temperature and coolant level
- 24 Volt stop solenoid (energised to run)

Flywheel and Housing

- High inertia flywheel to SAE J620 Size 14
- SAE ½ flywheel housing
- Position for magnetic speed sensor

Mountings

- Front mounting bracket

Literature

- User's Handbook and Parts Manual

Optional Equipment

- Barber-Colman Electric Governor
- 240 Volt/1500 Watt immersion heaters (2)
- Hours Counter
- Electric Tachometer with speed sensor
- Radiator mounting

General Data

Number of cylinders	8
Cylinder arrangement	90° vee form
Cycle	4-stroke
Induction system	Turbocharged and air-to-air charge cooled
Combustion system	Direct injection
Cooling system	Water-cooled
Bore and stroke	135 x 152 mm
Displacement	17.4 litres
Compression ratio	14.5:1
Direction of rotation	Anti-clockwise viewed on flywheel
Firing order	A1, B1, B2, A3, B3, A2, A4, B4
Total lubrication system capacity	60.7 litres
Total coolant capacity	71.6 litres
Dry weight (ElectropaK)	1725 kg
Length	1823 mm
Width	1400 mm
Height	1674 mm

Fuel Consumption

Engine speed	1500 rev/min		1800 rev/min	
	g/kWh	l/hr	g/kWh	l/hr
At Standby Maximum rating	220	122.6	–	–
At Prime Power rating	216	109.5	–	–
At Baseload rating	–	–	–	–
At 75% of Prime Power rating	213	81.1	–	–
At 50% of Prime Power rating	213	54.0	–	–

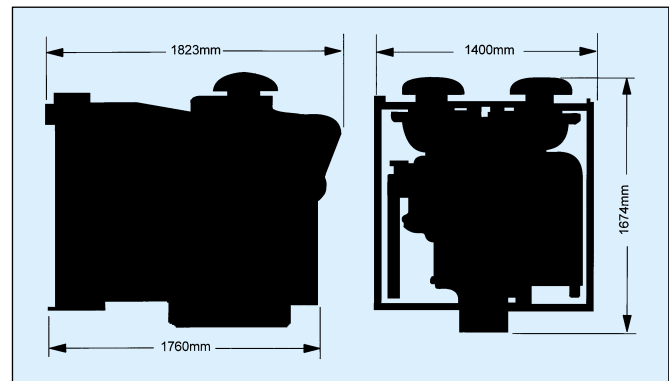

Perkins Engines Company Limited

Lancaster Road Shrewsbury SY1 3NX England
 Telephone (01743) 212000 Telex 35171 PESL G
 Fax (01743) 212700
www.perkins-engines.com

All information in this document is substantially correct at the time of printing but may be altered subsequently by the company.

Distributed by